

PARTS LIST			
ITEM	QTY	PART NUMBER	MATERIAL
1	1	BASE	CAST IRON
2	1	SLIDING JAW	CAST IRON
3	1	WISE SCREW	SAE 3140
4	2	SLIDE KEY	SAE 1020
5	2	JAW PLATE	SAE 3140
6	1	COLLAR	SAE 1020
7	1	SPECIAL KEY	SAE 1020
8	2	HANDLE BALL	SAE 1020
9	1	HANDLE ROD	COLD ROLLED STEEL
10	2	SET SCREW	SAE 1016
11	4	1/4 FLAT HEAD MACHINE SCREW	TYPICAL
12	2	#000 TAPER PIN	TYPICAL

MASTER ASSEMBLY
SCALE 1 : 1

LEGEND:

- ∅ DIAMETER
- R RADIUS
- ° DEGREES
- COUNTERBORE
- ∇ DEPTH
- ✓ COUNTERSINK

GENERAL NOTES:

ALL FILLETS AND ROUNDS ARE 1/8, UNLESS SPECIFIED



DIGITAL DESIGN
GRAPHICS
TECHNOLOGY

WWW.DDGT.NET

JOSEPH WILLIAMS



(707)673-6354
JOWILLIAMSASD@GMAIL.COM
WWW.DDGT.NET/STUDENTPAGES/JWILLIAMS

GRAPHIC DESIGNER

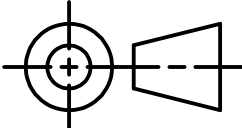

TOLERANCES UNLESS SPECIFIED:
DECIMAL INCHES:
X = ±.020
XX = ±.010
XXX = ±.005
FRACTIONAL ±1/64"
ANGLES ±1 DEGREE
SURFACES 32 ✓

COURSE:	DDGT240
INVENTOR DRAWING NAME:	MACHINE VISE
FIG #:	14-71
DRAFTER:	J.WILLIAMS
DATE:	9/5/2019
SCALE:	AS NOTED
PAGE #:	1 OF 5

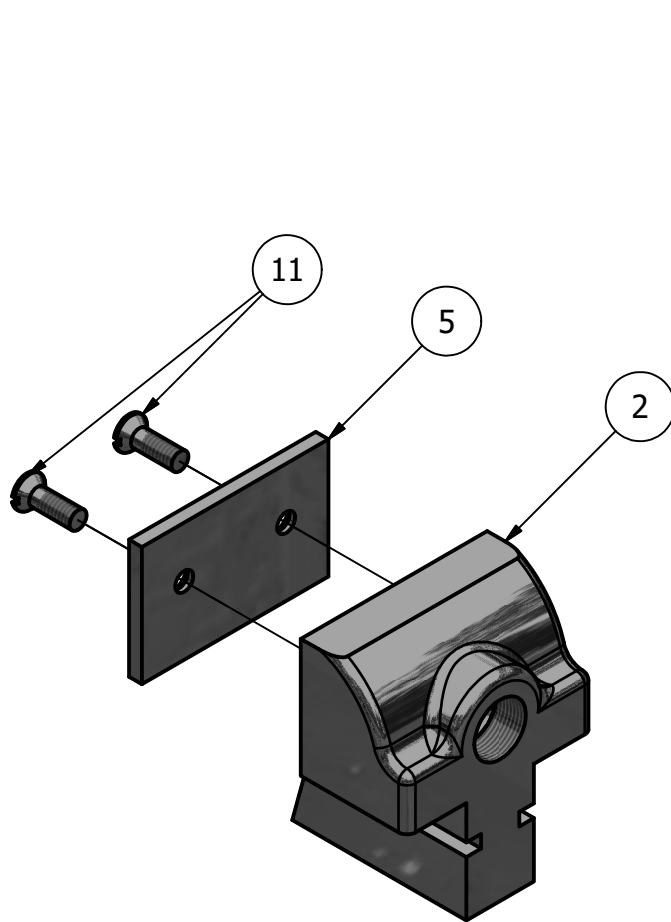

STEP 1
SCALE 1 / 2

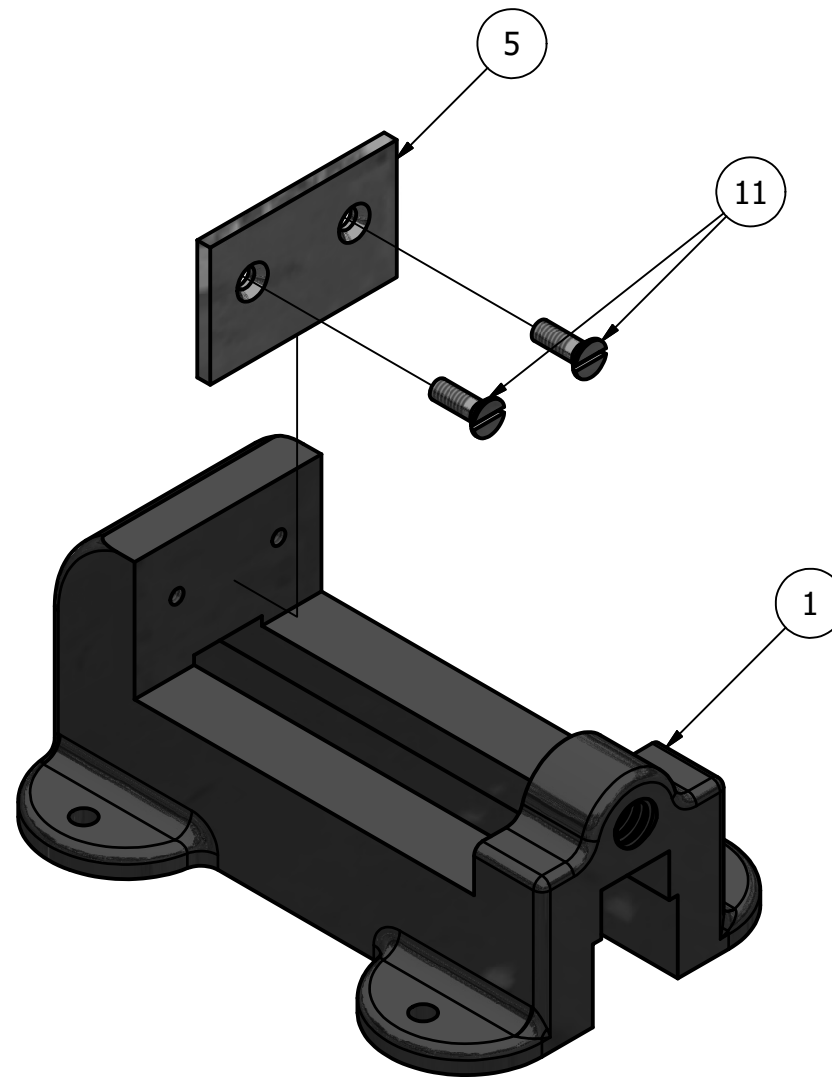

STEP 2
SCALE 1 / 2

PARTS LIST		
ITEM	QTY	PART NUMBER
1	1	BASE
2	1	SLIDING JAW
3	1	WISE SCREW
4	2	SLIDE KEY
5	2	JAW PLATE
6	1	COLLAR
7	1	SPECIAL KEY
8	2	HANDLE BALL
9	1	HANDLE ROD
10	2	SET SCREW
11	4	1/4 FLAT HEAD MACHINE SCREW
12	2	#000 TAPER PIN

LEGEND:

- ∅ DIAMETER
- R RADIUS
- ° DEGREES
- ┌ COUNTERBORE
- ∇ DEPTH
- ∨ COUNTERSINK

GENERAL NOTES:

ALL FILLETS AND ROUNDS ARE 1/8, UNLESS SPECIFIED



DIGITAL DESIGN
GRAPHICS
TECHNOLOGY

WWW.DDGT.NET

JOSEPH WILLIAMS



(707)673-6354

JOWILLIAMSASD@GMAIL.COM

WWW.DDGT.NET/STUDENTPAGES/JWILLIAMS

GRAPHIC DESIGNER

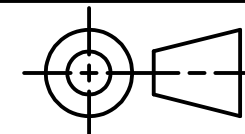

TOLERANCES UNLESS SPECIFIED:

DECIMAL INCHES:
X = ±.020
XX = ±.010
XXX = ±.005
FRACTIONAL ±1/64"
ANGLES ±1 DEGREE

SURFACES 32 ✓

COURSE: DDGT240

INVENTOR DRAWING NAME:
MACHINE VISE

FIG #: 14-71

DRAFTER: J.WILLIAMS

DATE: 9/5/2019

SCALE: AS NOTED

PAGE #: 2 OF 5

PARTS LIST		
ITEM	QTY	PART NUMBER
1	1	BASE
2	1	SLIDING JAW
3	1	WISE SCREW
4	2	SLIDE KEY
5	2	JAW PLATE
6	1	COLLAR
7	1	SPECIAL KEY
8	2	HANDLE BALL
9	1	HANDLE ROD
10	2	SET SCREW
11	4	1/4 FLAT HEAD MACHINE SCREW
12	2	#000 TAPER PIN

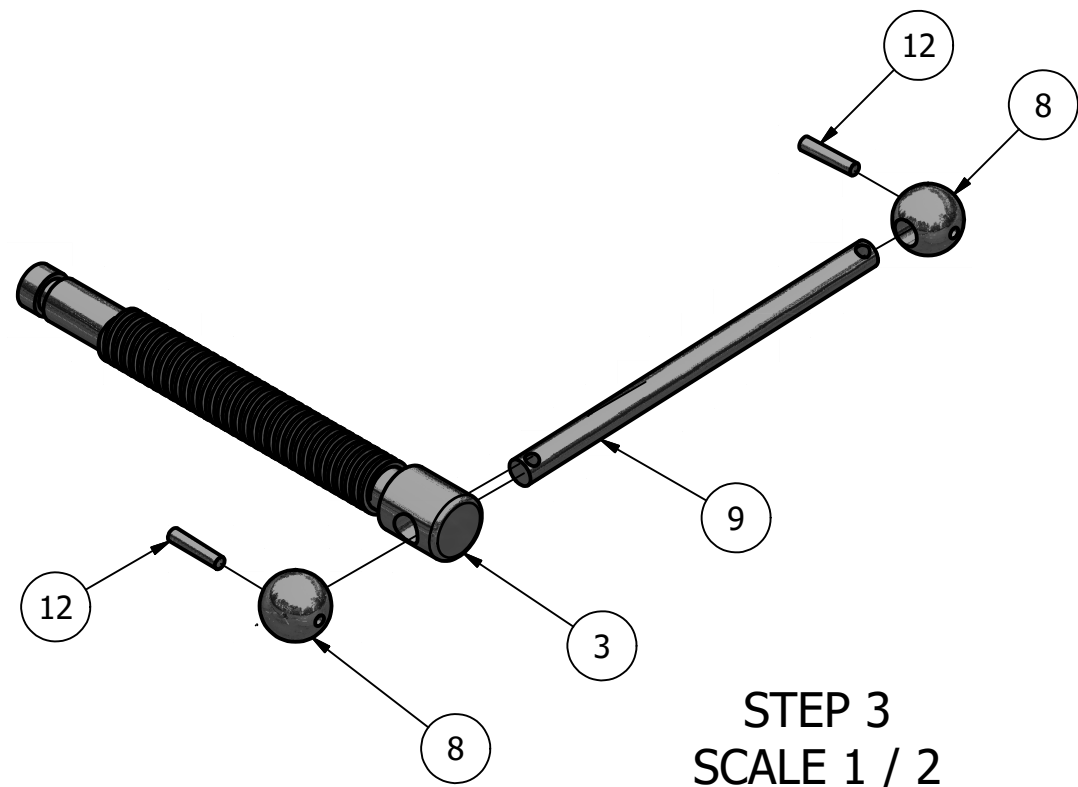

STEP 3
SCALE 1 / 2

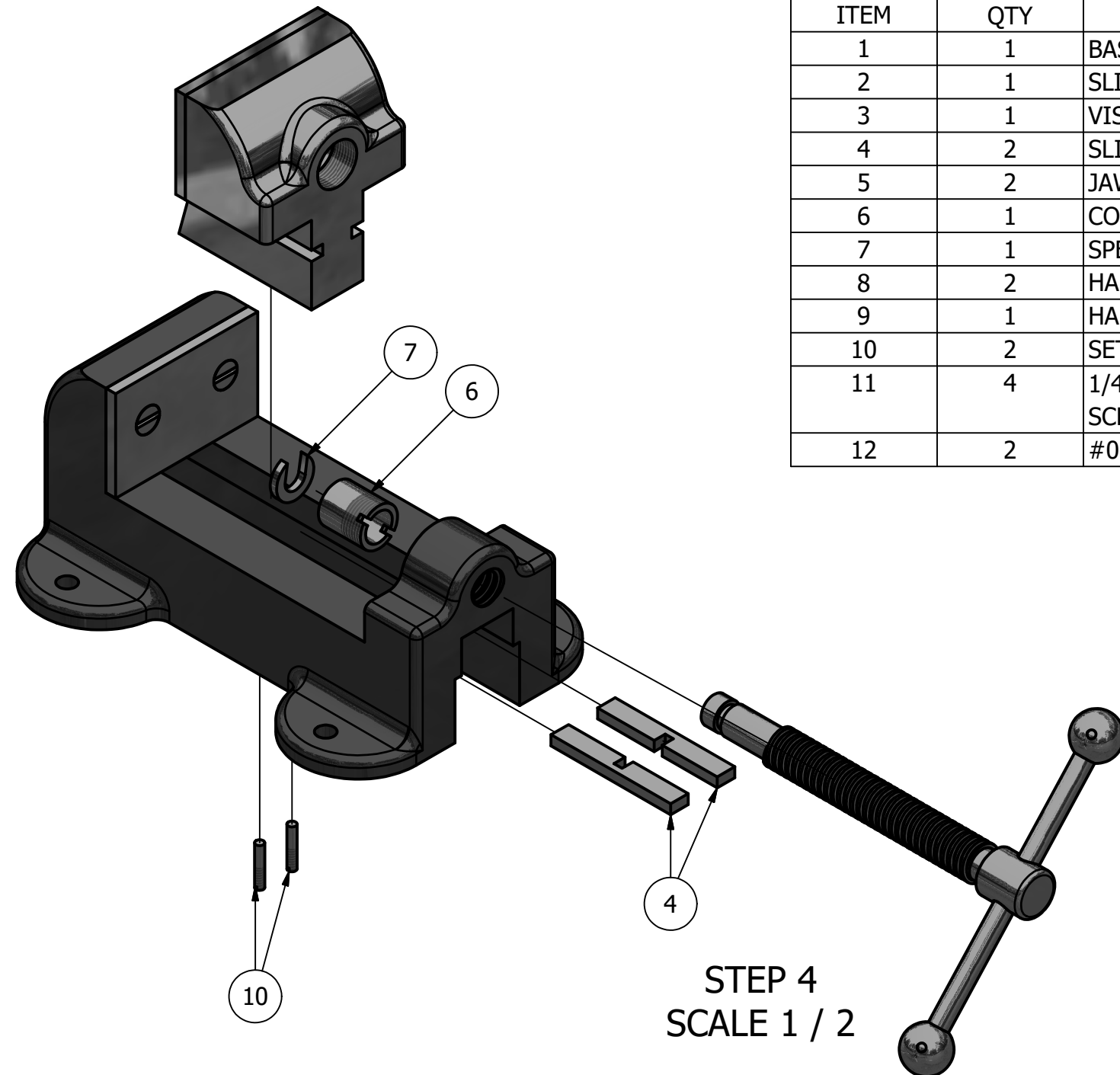

STEP 4
SCALE 1 / 2

LEGEND:

- ∅ DIAMETER
- R RADIUS
- ° DEGREES
- ┌ COUNTERBORE
- ∇ DEPTH
- ∨ COUNTERSINK

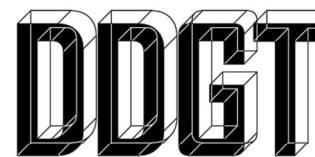

DIGITAL DESIGN
GRAPHICS
TECHNOLOGY

WWW.DDGT.NET

JOSEPH WILLIAMS



(707)673-6354

JOWILLIAMSASD@GMAIL.COM

WWW.DDGT.NET/STUDENTPAGES/JWILLIAMS

GRAPHIC DESIGNER

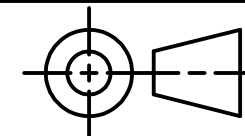

TOLERANCES UNLESS SPECIFIED:

DECIMAL INCHES:

X = ±.020

XX = ±.010

XXX = ±.005

FRACTIONAL ±1/64"

ANGLES ±1 DEGREE

SURFACES 32 ✓

COURSE: DDGT240

INVENTOR DRAWING NAME:

MACHINE VISE

FIG #: 14-71

DRAFTER: J.WILLIAMS

DATE: 9/5/2019

SCALE: AS NOTED

PAGE #: 3 OF 5

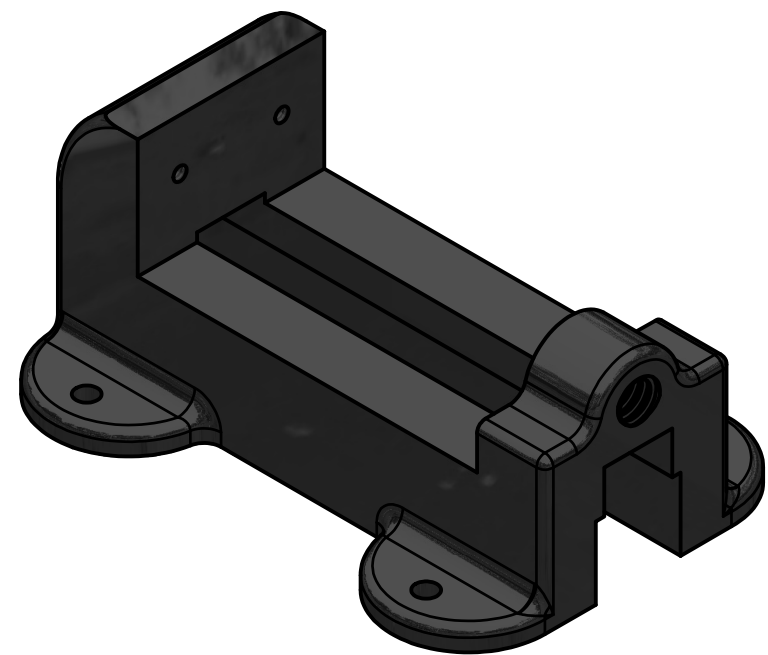
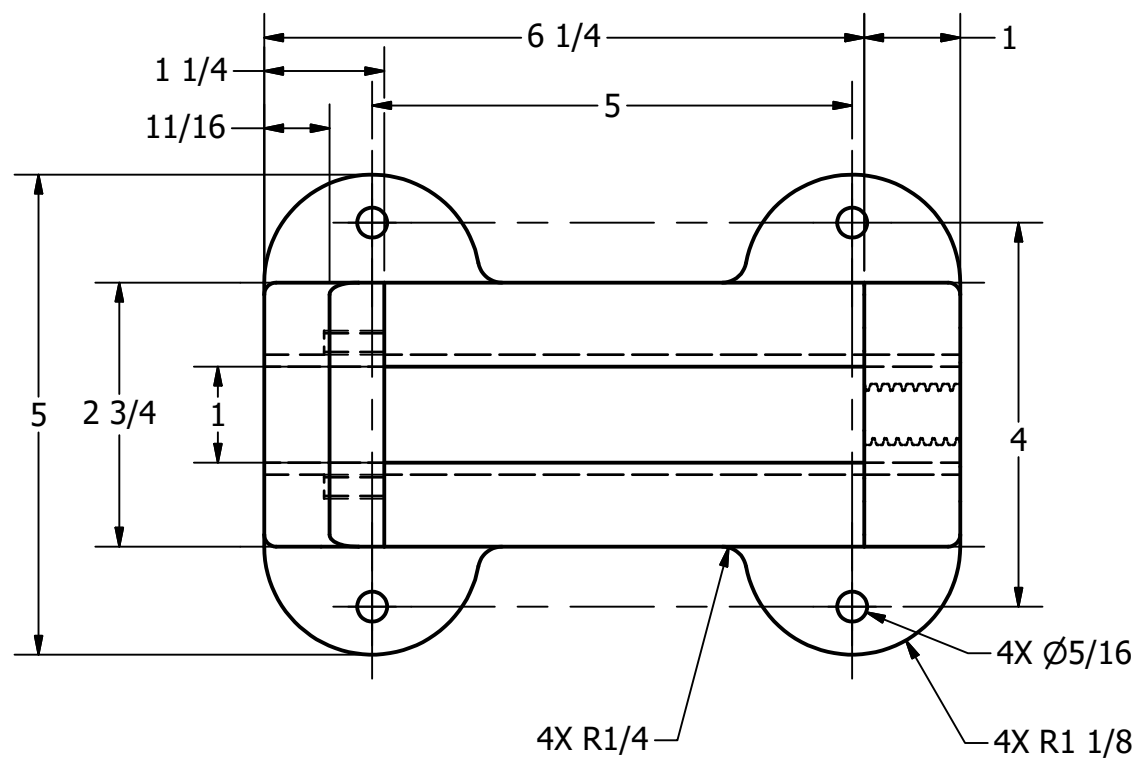

PARTS LIST		
ITEM	QTY	PART NUMBER
1	1	BASE
5	2	JAW PLATE
6	1	COLLAR
7	1	SPECIAL KEY

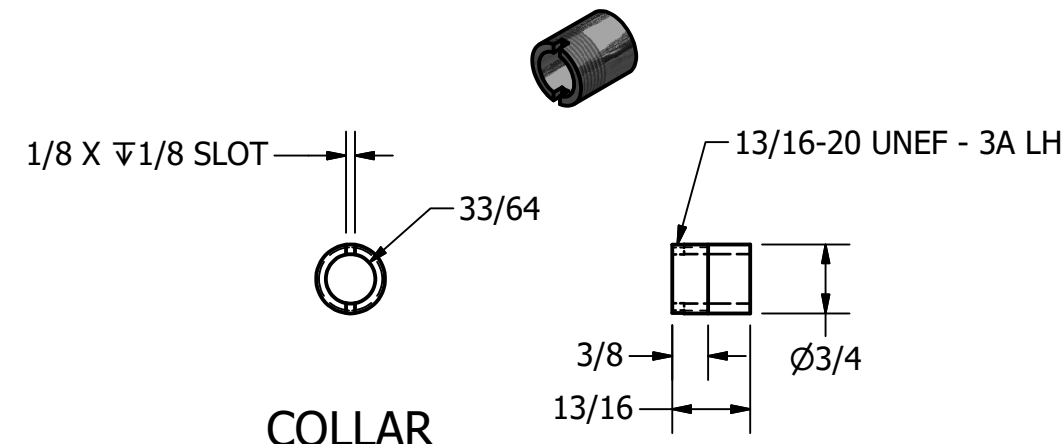

COLLAR
SCALE 1 / 2

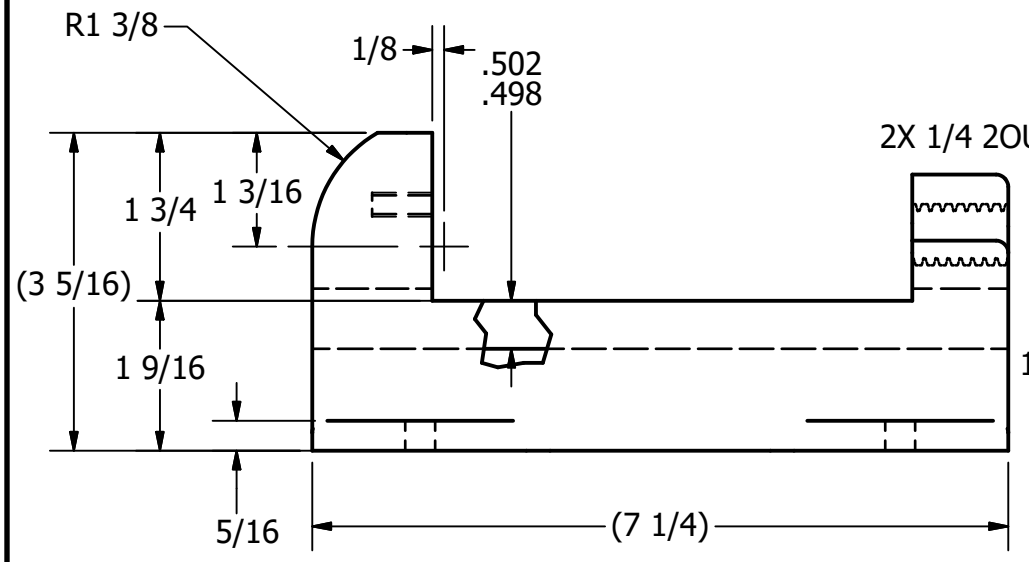

BASE
SCALE 1 / 2

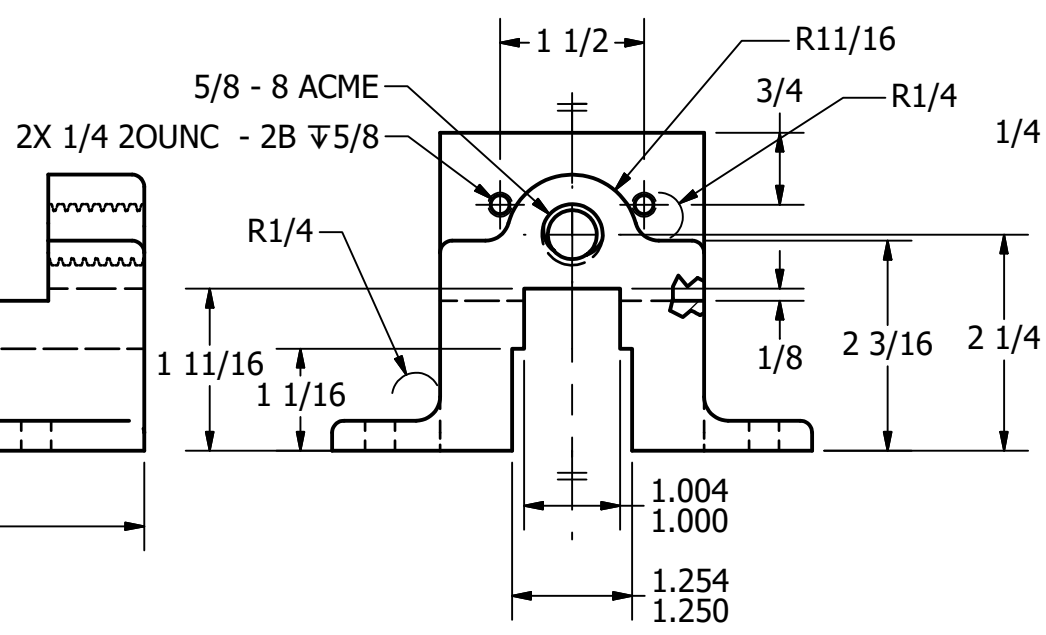

2X DRILL AND ∇ FOR
1/4 FLAT HEAD MACHINE SCREW

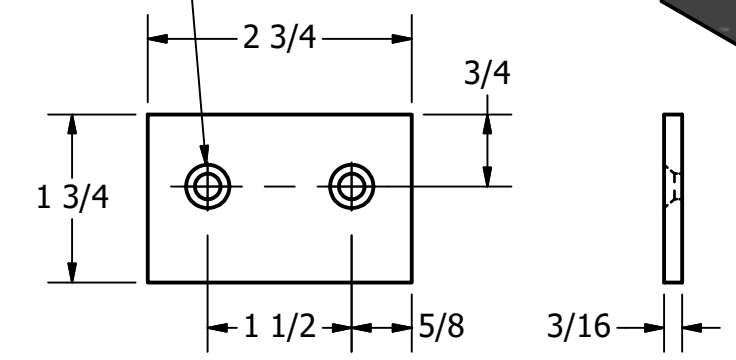

JAW PLATE
SCALE 1 / 2

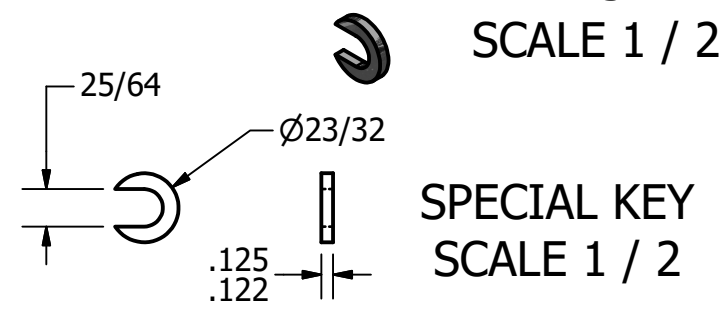

SPECIAL KEY
SCALE 1 / 2

- LEGEND:**
- Ø DIAMETER
 - R RADIUS
 - ° DEGREES
 - COUNTERBORE
 - ∇ DEPTH
 - ✓ COUNTERSINK

GENERAL NOTES:
ALL FILLETS AND ROUNDS ARE 1/8, UNLESS SPECIFIED

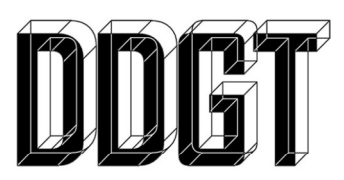

DIGITAL DESIGN
GRAPHICS
TECHNOLOGY

WWW.DDGT.NET

JOSEPH WILLIAMS



(707)673-6354

JOWILLIAMSASD@GMAIL.COM

WWW.DDGT.NET/STUDENTPAGES/JWILLIAMS

GRAPHIC DESIGNER

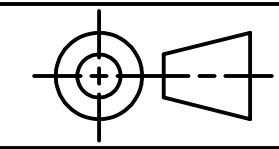

TOLERANCES UNLESS SPECIFIED:
DECIMAL INCHES:
X = ±.020
XX = ±.010
XXX = ±.005
FRACTIONAL ±1/64"
ANGLES ±1 DEGREE
SURFACES 32 ✓

COURSE: DDGT240

INVENTOR DRAWING NAME:
MACHINE VISE

FIG #: 14-71

DRAFTER: J.WILLIAMS

DATE: 9/5/2019

SCALE: AS NOTED

PAGE #: 4 OF 5

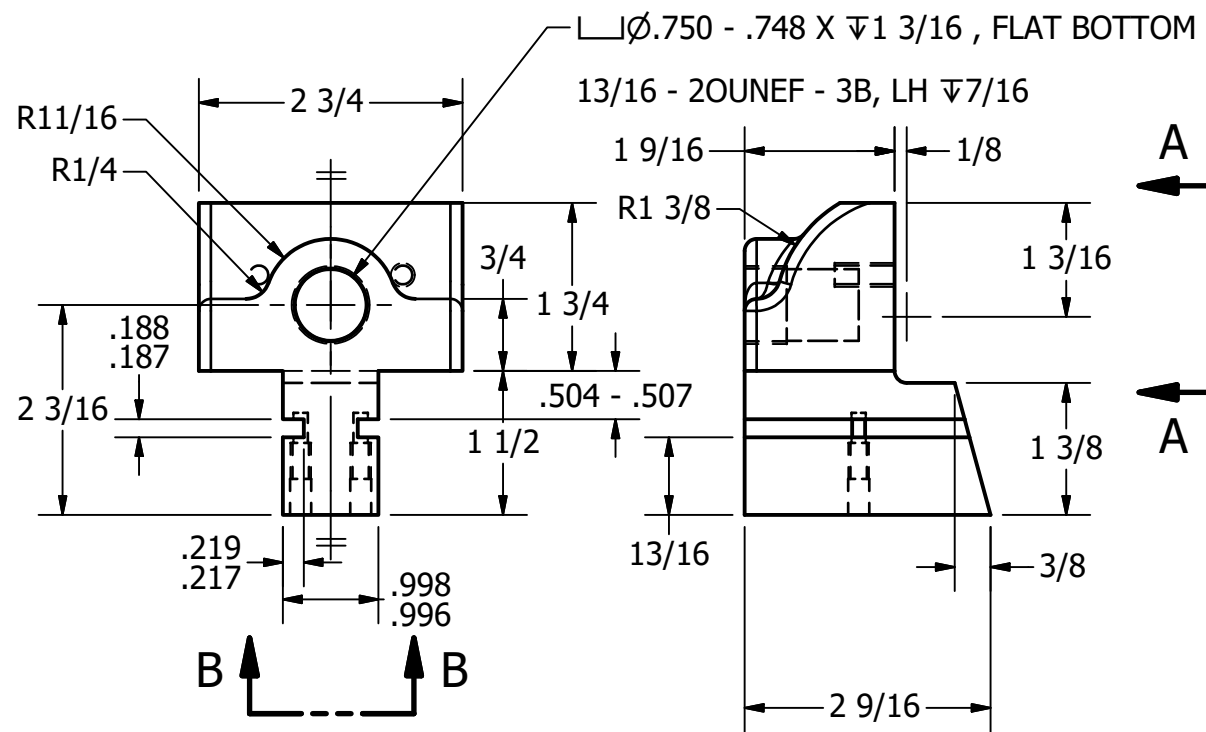

SLIDING JAW
SCALE 1 / 2

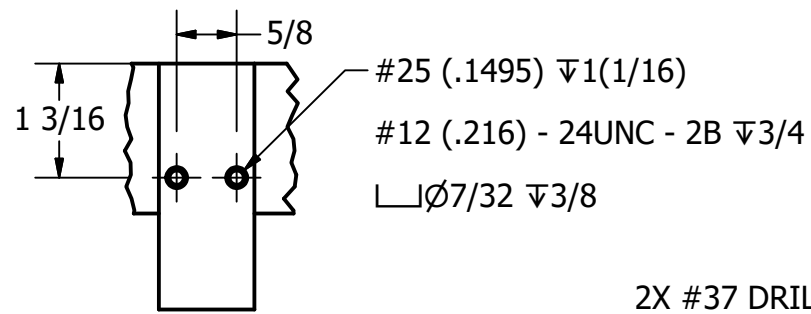

VIEW B-B
SCALE 1 / 2

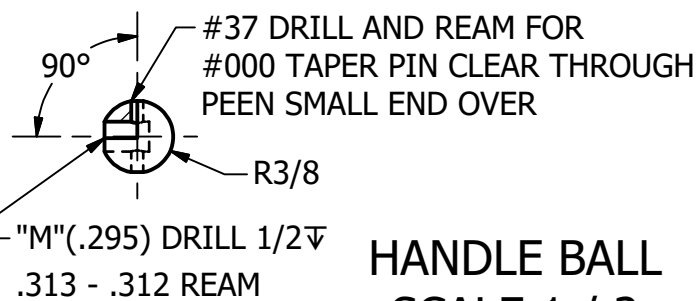

HANDLE BALL
SCALE 1 / 2

GENERAL NOTES:

ALL FILLETS AND ROUNDS ARE 1/8, UNLESS SPECIFIED

LEGEND:

- \varnothing DIAMETER
- R RADIUS
- $^\circ$ DEGREES
- \perp COUNTERBORE
- ∇ DEPTH
- \surd COUNTERSINK

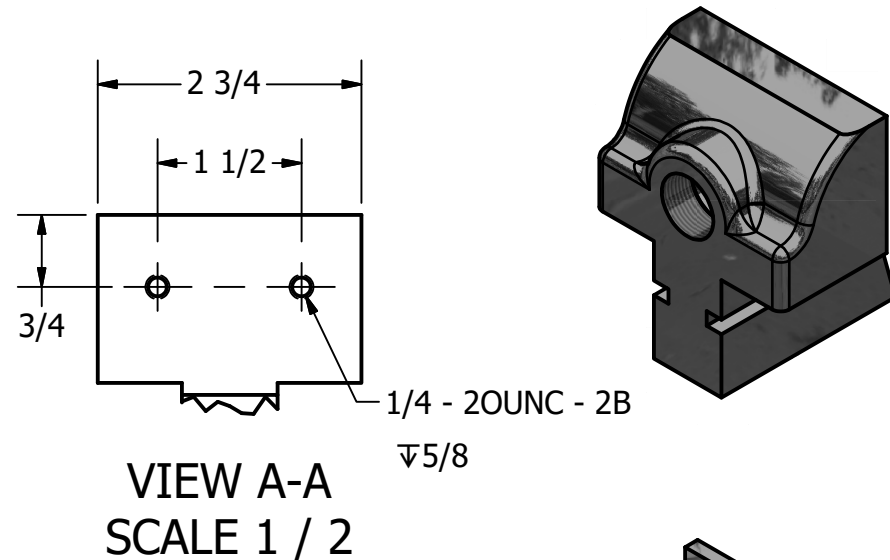

VIEW A-A
SCALE 1 / 2

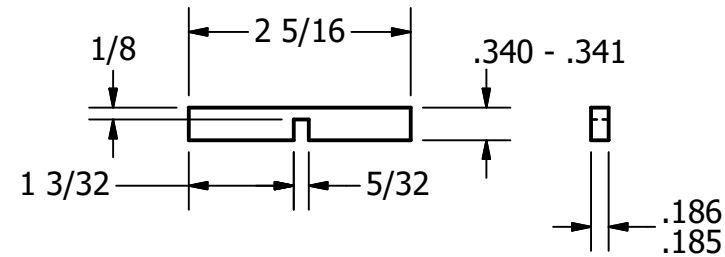

SLIDE KEY
SCALE 1 / 2

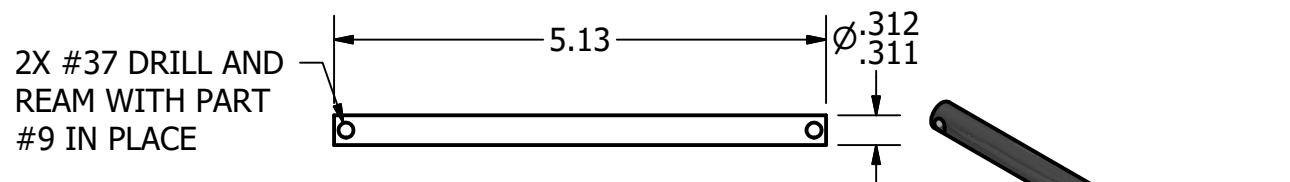

HANDLE ROD
SCALE 1 / 2

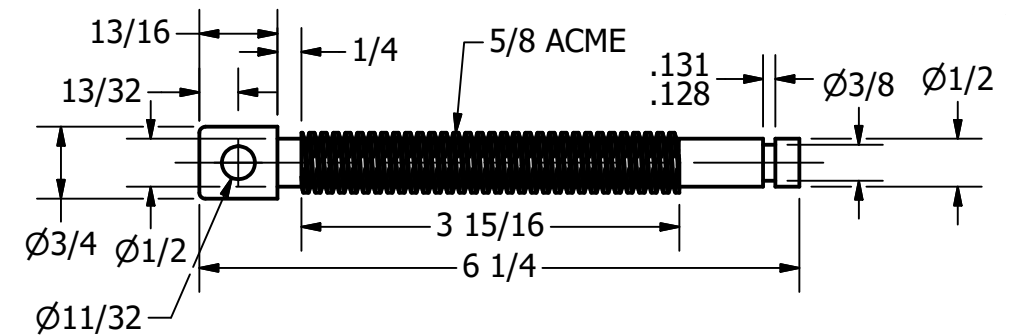

VICE SCREW
SCALE 1 / 2

PARTS LIST		
ITEM	QTY	PART NUMBER
2	1	SLIDING JAW
3	1	VICE SCREW
4	2	SLIDE KEY
8	2	HANDLE BALL
9	1	HANDLE ROD



DIGITAL DESIGN
GRAPHICS
TECHNOLOGY

WWW.DDGT.NET

JOSEPH WILLIAMS



(707)673-6354

JOWILLIAMSASD@GMAIL.COM

WWW.DDGT.NET/STUDENTPAGES/JWILLIAMS

GRAPHIC DESIGNER

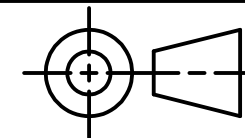

TOLERANCES UNLESS SPECIFIED:
 DECIMAL INCHES:
 X = ± 0.020
 XX = ± 0.010
 XXX = ± 0.005
 FRACTIONAL $\pm 1/64$ "
 ANGLES ± 1 DEGREE

SURFACES \surd 32

COURSE: DDGT240

INVENTOR DRAWING NAME:
MACHINE VISE

FIG #: 14-71

DRAFTER: J.WILLIAMS

DATE: 9/5/2019

SCALE: AS NOTED

PAGE #: 5 OF 5